

ATP/ATPR-FL SERIES

Current Transducers

ATP/ATPR-FL Series Powered High-Current Transducers are large-format solid-core transducers designed for high current applications from 200A to 2000A. Powered by 120VAC or 24VAC/VDC, these products take advantage of available power supplies and eliminate the need for costly control power transformers. Options include average responding and True RMS versions, 0–5/10VDC or 4–20 mA analog outputs and switch-selectable input ranges.

Applications

Commercial and Industrial MCC's

- Fits conveniently in motor control centers, senses current on industrial motors and provides analog inputs back to PLC or controller.

VFD or SCR Controlled Loads, Electronic Ballasts

- Helpful in monitoring VFD-controlled motors to provide operational status. ATR Series also provides accurate measurement of ballast input power and phase angle fired SCRs.

Large Pumping Applications

- Ideal for proof-of-flow in water/wastewater, boiler and other industrial pumping applications 1.50 HP and over. 120VAC or 24VAC/VDC supply options allow for powering off of readily available supply, eliminating need for CPTs.

Power Distribution Centers (PDCs)

- Monitors current output on commercial generation equipment and serves as a current input for use in power consumption calculations.

- For additional Sample Output/Power Supply or Application Examples, see Supplemental Illustrations on page A80.

Test & Evaluation Units

For OEMs

Free program expedites evaluation process. See page 1 for details.



Features

Large Aperture

- Accommodates large conductors or wire bundles.

Select the Right Output

- True RMS technology is accurate on distorted wave form like those associated with VFD or SCR outputs.
- Average Responding for use with linear, sinusoidal waveforms.

Jumper Selectable Ranges

- Reduces inventory.
- Eliminates zero and span pots.

Isolation

- Output is magnetically isolated from the input for safety.
- Eliminates insertion loss (voltage drop).

Centrifugal Pump Monitoring

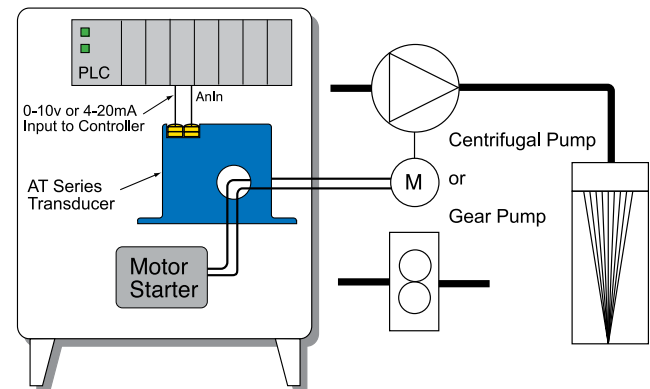

Dimensions

FL Case

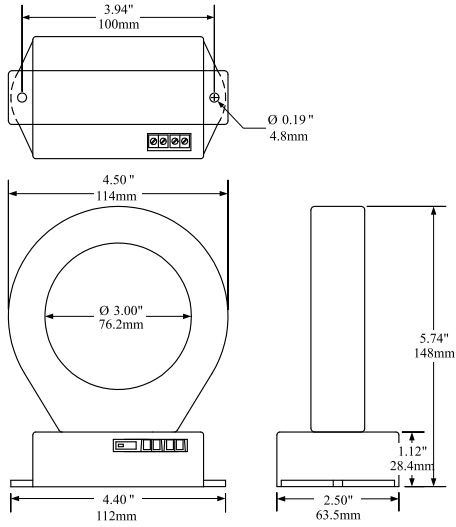

Connections

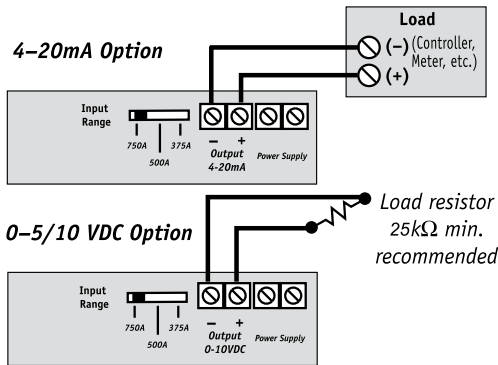

Notes:

Terminals are deadfront captive screw terminals. Use 12-22 AWG solid or stranded.

Specifications

Model	-005 Model	-010 Model	-420Model
Output Signal	0-5VDC	0-10VDC	4-20 mA
Output Limit	112% (5.6V)	112% (11.2V)	112% (22.4mA)
Loading	25K Ω min.: VDC Models 500 Ω max.: 4-20 mA Models		
Response Time	<ul style="list-style-type: none"> ATP: 100ms (10-90% step change) ATPR: 600ms (10-90% step change) 		
Frequency Range	<ul style="list-style-type: none"> ATP: 40-100Hz, Sinusoidal ATPR: 10-400Hz 		
Accuracy	1.0% FS		
Power Supply	120VAC or 24VAC/VDC, 2VA max		
Isolation Voltage	600VAC		
Input Ranges (switch selectable)	<ul style="list-style-type: none"> ATP3/ATPR3: 0-375A/500A/750A ATP4/ATPR4: 0-1000A/1333A/2000A 		
Sensing Aperture	3.0" (76.2mm) dia.		
Case	UL94 V0 Flammability Rated		
Environmental	5 to 122°F (-15 to 50°C) 0-95% RH, non-condensing		

Ordering Information

Sample Model Number: ATPR3-420-120-FL
True RMS AC current transducer, 24VDC, powered with a 4-20 mA output, 375/500/750A ranges in a fixed core case.



(1) Measurement

R	True RMS
	Average Responding (Blank)

(2) Full Scale Range

3	375-750A
4	1000-2000A

(3) Output Signal

005	0-5VDC
010	0-10VDC
420	4-20 mA

(4) Power Supply

24U	24VAC/DC
120	120VAC

(5) Case Style

FL	Solid-core
----	------------

