

## Specifications

Current Ranges	Field Selectable Ranges (See Model Number Key)
Custom Ranges	Available; consult factory.
Output Signal	4-20mA, 0-5VDC or 0-10VDC
Accuracy	1% FS
Output Polarity	Unipolar: Current magnitude only Bipolar: Current direction indication
Isolation Voltage	3kV (Monitored line to output)
Linearity	0.75%
Response Time	100 mS (to 90% of step change)
Repeatability	1% FS
Power Supply	20-45VDC or 22-38 VAC    Power and output signal are not isolated. Caution: Connecting AC supply to output negative may damage output.
Power Consumption	2 VA
Case	UL 94V-0 Flammability rated thermoplastic
Environmental	-20 to 50 Deg. C, 0-95% RH, non-condensing
Temperature Drift	0.01% / Deg C

## Output Polarity

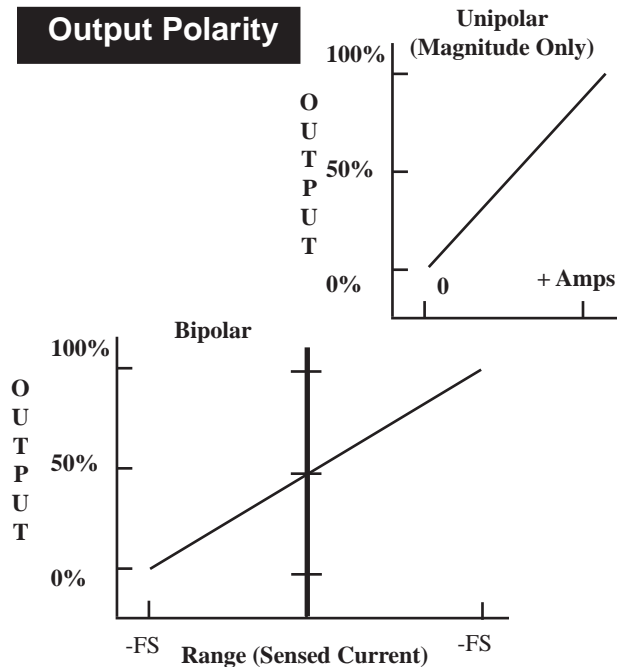

## Model Number Key

DT 1 - 420 - 24U - U - SP

**CASE STYLE**  
SP- Split Core

**OUTPUT POLARITY**  
U- Unipolar (Magnitude)  
BP - BiPolar

**POWER SUPPLY:**  
24U- 24 VAC or VDC (Universal)

**OUTPUT:**  
005- 0-5 VDC  
010 0-10 VDC  
020 0-20 mA  
420 4-20 mA

### RANGE

1 50, 75, 100 A  
2 100, 150, 200 A  
3 150, 225, 300 A  
4 200, 300, 400 A

### SENSOR TYPE:

DT - DC current sensor with analog output

## Know Your Power



**Other NK Technologies Products Include:**  
DC Current Switches, Ground Fault Sensors  
AC & DC Current Switches  
Power Transducers  
Current & Potential Transformers (CTs&PTs)



3511 Charter Park Drive, San Jose, CA 95136  
800-959-4014 or +1-408-871-7510 Phone  
+1-408-871-7515 FAX  
sales@nktechnologies.com, www.nktechnologies.com



# INSTRUCTIONS



**DT SERIES**  
Uni-Polar or BiPolar  
4-20mA or 0-5/0-10VDC Output

## Quick "How To" Guide

- Route wire to be monitored through aperture. Ensure current flow matches any arrow on sensor.
- Mount the sensor to a surface if needed.
- Connect output wiring.
 

**Caution: Do not connect grounded AC supply to Output negative terminal. This may damage sensor output circuitry.**

  - Use up to 14 AWG copper wires. Tighten terminals to 4 inch-pounds torque.
  - For mA output models, make sure output load is no more than 800 Ω.
  - For VDC output models, make sure output load is at least 10KΩ.
- Connect Power
  - Connect the appropriate power supply.
- Select Range
  - Chose correct range by positioning the Range Jumper.

## Description

DT Series transducers combine a Hall Effect sensor and a signal conditioner into a single package. This provides higher accuracy, lower wiring costs, easier installation and saves valuable panel space. DT Series are available in split core with 0-20mA, 4-20mA, 0-5VDC or 0-10 VDC outputs.

## Installation

### For All Versions

Run wire to be monitored through opening in the sensor. Be sure the monitored current flows in the same direction as indicated by arrow on sensor. The arrow is just above the hinge, with the “+” symbol on the left, the “-” symbol on the right on the unipolar designs; bipolar models accept current flow in both directions.

DT Series transducers work in the same environment as motors, contactors, heaters, pull-boxes, and other electrical enclosures. They can be mounted in any position or hung directly on wires with a wire tie. Just leave at least one inch distance between sensor and other magnetic devices.

### Split-Core

Press the tab in the direction as shown to open the sensor. After placing the wire in the opening, press the hinged portion firmly downward until a definite click is heard and the tab pops out fully.

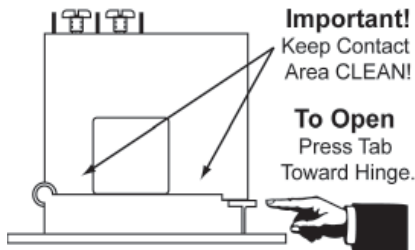

### KEEP SPLIT-CORE SENSORS CLEAN.

Silicone grease is factory applied on the mating surfaces to prevent rust and improve performance. Be careful not to allow grit or dirt onto the grease in the contact area. Operation can be impaired if the mating surfaces do not have good contact. Check visually before closing.

## Output Wiring

Connect control or monitoring wires to the sensor. Use up to 14 AWG copper wire and tighten terminals to 4 inch-pounds torque.

### 0-20mA & 4-20mA:

The current loop is powered by the DT Transducer.

Maximum loop impedance is 650  $\Omega$ .

### 0-5VDC & 0-10 VDC:

Signal is powered by the DT Transducer. Minimum output load (impedance) is 25K  $\Omega$  for the 5V and 50K  $\Omega$  for the 10 volt models.

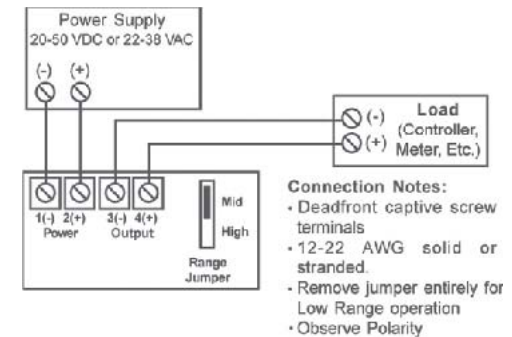

## Range Select

DT Series transducers feature field selectable ranges. The ranges are factory calibrated, eliminating time consuming and inaccurate field setting of zero or span.

1. Determine the normal operating amperage of your monitored circuit

2. Select the range that is equal to or slightly higher than the normal operating amperage.
3. Place the range jumper in the appropriate position.
4. If the sensor uses three pins, low range is selected by removing the jumper. If it uses four pins, the label will indicate where to place the jumper for each range.

## Trouble Shooting - 0-20 & 4-20mA Models

### 1. Output Signal Too Low

- A. The jumper may be set in a range that is too high for current being monitored. *Move jumper to the correct range.*
- B. Power supply is inadequate. *Check power supply. Make sure it is of sufficient voltage with all loads at maximum. DT Series draw 2.0 VA.*
- C. Output load too high *Check output load, be sure it is no more than 650  $\Omega$  for current output models.*

### 2. Output Signal is always at maximum

- A. The jumper may be set in a range that is too low for current being monitored. *Move jumper to the correct range.*

### 3. Sensor has no output

- A. Polarity is not properly matched. *Check and correct wiring polarity*
- B. Monitored load is not DC or is not on. *Check that the monitored load is DC and that it is actually on.*
- C. Split Core models: The core contact area may be dirty. *Open the sensor and clean the contact area.*

## Trouble Shooting - 0-5VDC & 0-10 VDC Models

### 1. Output Signal Too Low

- A. The jumper may be set in a range that is too high for current being monitored. *Move jumper to the correct range.*
- B. Power supply is inadequate. *Check power supply. Make sure it is of sufficient voltage with all loads at maximum. DT Series draw 2.0 VA.*
- C. Output load too low. *Check output load, be sure it is at least 25K  $\Omega$  for 5VDC or 50K  $\Omega$  for 10 VDC.*

### 2. Output Signal is always at maximum

- A. The jumper may be set in a range that is too low for current being monitored. *Move jumper to the correct range.*

### 3. Sensor has no output

- A. Polarity is not properly matched. *Check and correct wiring polarity*
- B. Monitored load is not DC or is not on. *Check that the monitored load is DC and that it is actually on.*
- C. Split Core models: The core contact area may be dirty. *Open the sensor and clean the contact area.*