

Specifications

Setpoint Range	AGL1 Series: 5-100mA Field Adjustable AGL2 Series: 80-950mA Field Adjustable AGL3 Series: Tri-Set, 5, 10 & 30 mA, Jumper Select
Voltage Range	Up to 1,500 VAC (Monitored Circuit)
Frequency Range	50-400Hz (Monitored Circuit)
Output Description:	Electromechanical relay 1.0A @ 120 VAC, 2A @ 30 VDC Status (Red) LED = Relay has operated
Response Time	200 ms @ 5% over setpoint. 60 ms @ 50% over setpoint. 15 ms @ 500% over setpoint
Power Supply	120 VAC Operates from 66-132 VAC (50-400hz)
Optional Power	24 VAC or 24 VDC Operates from 19.2-28.8 Volts) Power (Green) LED=Power supply energized
Power Consumption	2.5 Watts
Dimensions	4.25"H x 3.0"W x 3.25"D, (108x76x83mm), aperture 1.82" (46mm) dia.
Case	UL 94V-O Flammability Rated
Environmental	5 to 158 DegF (-15 to 70 DegC), 0-95% RH, Non Condensing
Terminal torque	5.3 inch-pounds

Power Supply Notes

All low-current Ground-Fault Sensors are sensitive devices that require reasonable care in system design to avoid false trips caused by high electrical noise levels. Keep in mind that the best way to reduce noise in a system is to suppress it at its source.

1. Keep the sensor power isolated from noisy circuits.
2. Do not power the sensor with the same circuit that switches contactors or other high current, inductive loads.

System Grounding

Good design practice and code require that all AC power systems be grounded. AGL Series sensors are designed to work on grounded AC power systems. They may not operate properly on ungrounded systems.

Model Number Key

AGL1 - NOR1 - 120 - LA - 005-N

					Options None (Blank) N Electrical Noise Immun.
				Setpoint 005 to 950	Factory Adjusted Setpoint in mA (specify when ordering)
				TR3	Tri-Set, 5, 10 & 30 mA, Jumper Select
				Options LA Normally De-energized	
				Power Supply 24U 24 VAC/DC 120 120 VAC	
				Output Type NOR1 SPST (Normally open, closes on fault) NCR1 SPST (Normally closed, opens on fault)	
				Setpoint Range 1 5-100mA, Adjustable 2 80-950mA, Adjustable 3 Tri-Set, 5, 10 & 30 mA, Jumper Select	

AGL Series Ground Fault Sensor

Know Your Power



Other NK Technologies Products Include:

AC & DC Current Transducers
AC & DC Current Operated Switches
1φ & 3φ Power Transducers
Current & Potential Transformers (CTs&PTs)



NK Technologies

3511 Charter Park Drive, San Jose, CA 95136 Toll free:
800-959-4014, Phone: 408-871-7510
Fax: 408-871-7515
sales@nktechnologies.com, www.nktechnologies.com



INSTRUCTIONS



AGL1, 2 & 3 SERIES Ground Fault Sensors with Latching Relay Outputs

Quick "How To" Guide

1. **Run all current carrying conductors through sensor window**
 - A. Use an auxiliary CT if conductors do not fit. Consult Factory for CT selection.
2. **Mount the sensor to a surface if needed.**
3. **Connect output & power wiring.**
 - A. Use up to 14 AWG copper wires.
 - B. Make sure power and load matches those shown on the sensors' label.
4. **Test**
 - A. Pressing the "TEST" button tests the sensors internal circuits. CAUTION: The output and any connected loads will switch!

Description

AGL Series sensors monitor all current carrying wires in single or three phase systems to detect ground faults. They provide a contact output that can operate relays, contactors or signal automation systems.

Principal of Operation

Under normal conditions, the current in one wire of a two wire load is equal in strength but opposite in sign to the current in the other wire. The two wires create magnetic fields that cancel, a condition known as “Zero Sum Current”. If any current leaks to ground (Ground Fault), the two currents become unbalanced and there is a net resulting magnetic field. The AGL sensor detects this minute field and changes the output state. This concept extends to three phase systems such as 3 wire Delta and to 4 wire Wye.

Single Phase (Phase & Neutral or Phase to Phase)

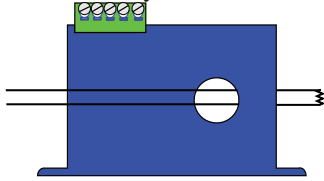

3 Phase Delta (Include neutral if the load uses neutral)

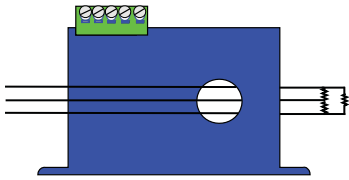

3 Phase Wye (Include neutral if load uses neutral)

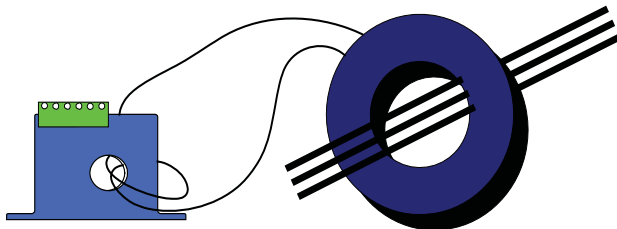
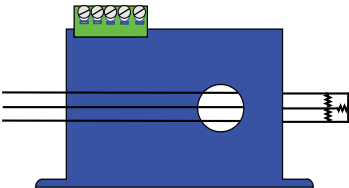

3 Phase Load, using an auxiliary Current Transformer. Contact factory for details.

Installation & Wiring

AGL Series sensors work in the same environment as motors, contactors, heaters, pull-boxes, and other electrical enclosures. They can be mounted in any position or hung directly on wires with a wire tie. Just leave at least one inch distance between sensor and other magnetic devices. Run all current carrying conductors through the opening in the sensor. (See “Principal of Operation”) Be Sure all wires are oriented so current flows in the same direction.

Wiring

Use up to 14 AWG copper wire and tighten terminals to 5.3 inch-pounds torque. See Diagram.

Power

Connect power wiring to Terminals 3 & 4. Be sure that the power supply matches the power rating on the sensor label. Green LED (Power) will light.

Output

Connect output wiring to Terminals 5 & 6.

Reset Switch

Connect a momentary dry contact to the reset terminals (1& 2.) Limit wire run to 200’ of 18 AWG or larger wire.

Operation

AGL Series Latching Ground fault sensors operate in one of two states: Reset or Latched. If control power is removed, the sensor remains in it’s last state (latched or reset). The sensor will unlatch if the power supply is cycled off and then on again.

To test operation, gently press the TEST button. This simulates a fault and tests the internal switching circuits.

CAUTION: Any circuit connected to the sensor will be operated.

The normally open contact closes on sensed fault current over the set point, and the normally closed contact opens on fault.

The triple range, field selectable models use a jumper to select the trip point. With the jumper off the pins, the sensor will trip at the lowest set point. The jumper can be placed over two pins to set the trip point at the medium level, or the other two pins to be set at the highest trip point.

Momentary Reset

The sensor will not work properly if the reset terminals are closed (shorted) continuously. Only close the reset terminals momentarily.

Parallel Reset Connection

Multiple sensors may be connected to the same reset switch in parallel. Only the sensors that have detected a fault and have latched will be reset. A sensor will not reset unless the fault has dropped below setpoint.

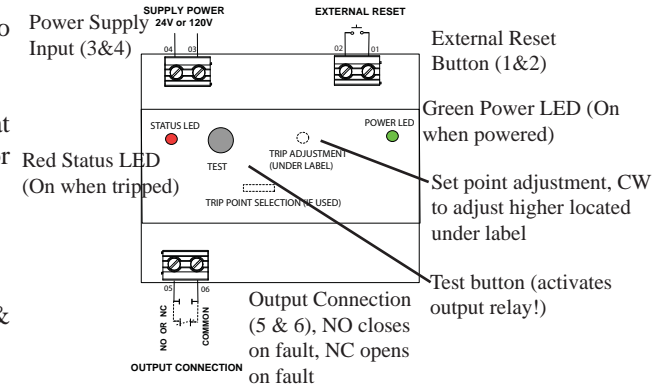

Field Setpoint Adjustment

While not as precise as having it set at the factory, the set point can be adjusted in the field through use of the small potentiometer located beneath the label to the right of the leads exiting the case. Though not recommended, if a field adjustment of setpoint is desired, the recommended steps are as follows:

1. Develop a load of the magnitude at which you want the sensor to trip; e.g., a 4000 ohm resistor at 120 VAC should provide a load of 30 mA while 4 watt “night light” bulb would create a load of approximately 3.333 mA.

2. With the load energized and passing through the sensing aperture, turn the potentiometer clockwise (CW) until the sensor trips. Then turn the pot back (CCW) one eighth of a turn.

NOTE: The tri-set models cannot be adjusted higher nor lower than the factory settings. When used with an external CT, the sensor will be set to trip at a point much lower than without the CT. This set point adjustment should be done with the load passing through the CT in that application.