

## Specifications

Current Ranges	Field Selectable from 0-2000A (See Model Number Key)
Output Signal	4-20mA, Loop Powered
Output Limit	23 mA
Accuracy	1.0% FS
Measurement	True RMS or Average Responding (See Model Number Key)
Frequency Range	ATR: 10-400 Hz AT: 50-60 Hz, Sinusoidal
Isolation Voltage	3kV
Response Time	500 ms (to 90% of step change)
Power Supply	24VDC nominal, 40VDC max.
Case	UL 94V-0 Flammability rated thermoplastic
Listing	UL and ULC Listed CE Certified

## Power Supply

Minimum Power Supply = 12 VDC + Total Loop Voltage Drop

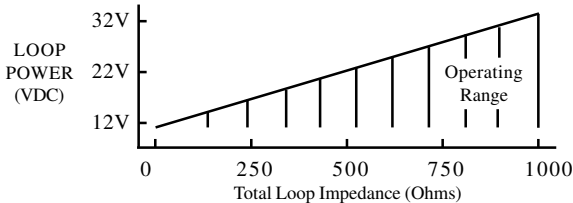

## Input Maximums

MODEL	RANGE	-----MAXIMUM AMPS-----		
		1 SEC	6 SEC.	CONTINUOUS
AT3	All	3,750A	1,500A	750A
ATR3	All	3,750A	1,500A	750A
AT4	All	10,000A	4,000A	2,000A
ATR4	All	10,000A	4,000A	2,000A

## Model Number Key

AT R 3 - 420 - 24L - FL

				<b>CASE STYLE</b>
				FL- Fixed core
				<b>POWER SUPPLY:</b>
				24L- 24VDC Loop Powered
				<b>OUTPUT:</b>
				420 - 4-20mA
				<b>RANGE</b>
				3 - 375, 500, 750 A
				4 - 1000, 1333, 2000 A
				<b>Measurement</b>
				R True RMS
				(Blank) Average Responding

## SENSOR TYPE:

AT - AC current sensor, 4-20 mA output  
loop powered

## Know Your Power



### Other NK Technologies Products Include:

AC & DC Current Transducers  
AC & DC Current Operated Switches  
1φ & 3φ Power Transducers  
Current & Potential Transformers (CTs&PTs)



## NK Technologies

500 Division Street, Campbell CA 95008-3606

Phone: 800-959-4014 or 408-871-7510

Fax: 408-871-7515

sales@nktechnologies.com, www.nktechnologies.com



# INSTRUCTIONS



## AT & ATR 3 & 4 SERIES

AC Current Transducers

4-20mA Output

True RMS or Average Responding

## Quick "How To" Guide

1. Run the wire you are monitoring through aperture.
2. Mount the sensor to a surface if needed.
3. Connect output wiring.
  - A. Use up to 14 AWG copper wires.
  - B. Make sure output load does not exceed product specifications.
  - C. Connect 24 VDC power supply and load in series.
4. Select Range
  - A. Chose correct range by positioning the Range switch.

## Description

AT and ATR Series transducers combine a current transformer and a signal conditioner into a single package. This provides higher accuracy, lower wiring costs, easier installation and save valuable panel space. AT Series are available in solid core with 4-20mA outputs.

ATR Series feature a True RMS output. They are designed for application on distorted current waveforms such as VFD outputs.

## Installation

Run wire to be monitored through the sensing aperture.

AT and ATR Series transducers work in the same environment as motors, contactors, heaters, pull-boxes, and other electrical enclosures. They can be mounted in any position or hung directly on wires with a wire tie. Just leave at least one inch distance between sensor and other magnetic devices.

## Output Wiring

Connect control or monitoring wires to the sensor. Use up to 14 AWG copper wire and tighten terminals to 3.5 inch-pounds torque. Be sure the output load does not exceed 800 ohms.

### Connection Notes:

- Captive screw terminals.
- 14-22 AWG solid or stranded.
- Observe Polarity
- See label for ranges & jumper positions

Single Transducer Installation

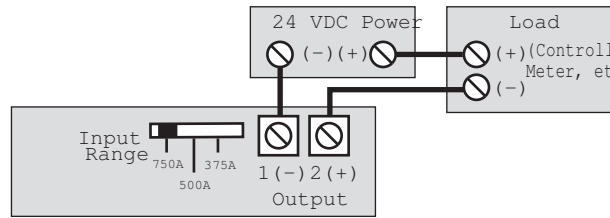

Powering Multiple Transducers from One Power Supply

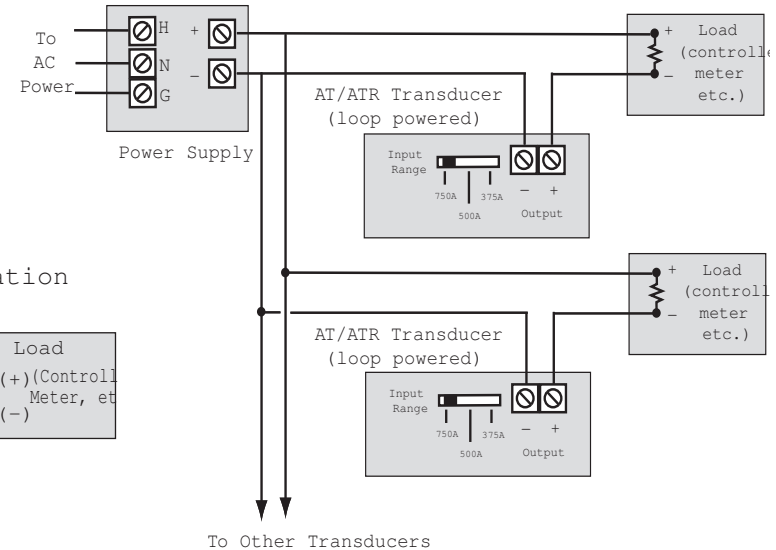

## Range Select

AT and ATR Series transducers feature field selectable ranges. The ranges are factory calibrated, eliminating time consuming and inaccurate field setting of zero or span.

1. Determine the normal operating amperage of your monitored circuit
2. Select the range that is equal to or slightly higher than the normal operating amperage.
3. Move the three position range selector switch to the appropriate position.

## Trouble Shooting

### 1. Sensor has no output

- A. Power supply is not properly sized. Check power supply voltage and current rating.
- B. Polarity is reversed. Check and correct wiring polarity.

### 2. Output Signal Too Low

- A. The jumper may be set in a range that is too high for current being monitored. Move jumper to the correct range.
- B. The load current is not sinusoidal. Select an ATR transducer for use with distorted waveforms.

- A. Monitored current is below minimum required. Loop the monitored wire several times through the aperture until the "sensed" current rises above minimum.  $\text{Sensed Amps} = (\text{Actual Amps}) \times (\text{Number of Loops})$ . Count loops on the inside of the aperture.

### 3. Sensor is always at 4mA

- A. Monitored load is not AC or is not on. Check that the monitored load is AC and that it is actually on.

### 4. Output Signal is always at 20mA

- A. The jumper may be set in a range that is too low for current being monitored. Move jumper to the correct range.