

Specifications

Output Signal	4-20mA, 0-5VDC, 0-10VDC (See Model Number Key)
Output Limit	112% of standard output range maximum value
Frequency Range	40-400Hz
Response Time (90% of step change)	100ms
Accuracy	0.25% FS
Loading	4-20mA models: 500 Ω 0-5/10VDC models: 250K Ω
Power Supply	24VAC/DC Nominal, 40 Volts Max. See "Output Wiring" section.
Output Load	500W maximum
Isolation Voltage Case	UL listed to 1,270VAC, tested to 5kV UL 94V-0 Flammability rated thermoplastic
Environmental	-20 to 50 Deg. C, (-4-122 Deg F) 0-95% RH, non-condensing
Listing	CE, UL 508 Industrial Control Equipment (Pending, USA & Canada)

Input Maximums

MAXIMUM INPUT AMPS

MODEL	RANGE	6 SEC.	1 SEC.
ATP0	0-2A	125	250
ATP0	0-5A	125	250
ATP1	0-10A	125	250
ATP1	0-20A	150	300
ATP1	0-50A	215	400
ATP2	0-100A	300	600
ATP2	0-150A	450	800
ATP2	0-200A	500	1,000

Model Number Key

ATP 1 - 420 - 24U - SP

CASESTYLE

FF- Fixed core, Front Terminals
SP- Split Core

POWER SUPPLY:

120- 120VAC with isolated output
24U- 24VAC/DC with non-isolated
output

OUTPUT:

420- 4-20mA
005- 0-5VDC
010- 0-10VDC

RANGE

0 - 2 & 5 Amps
1 - 10, 20 or 50 Amps
2 - 100, 150 or 200 Amps

SENSOR TYPE:

ATP - AC current transducers, 120VAC or 24VAC/DC
powered

Know Your Power



Other NK Technologies Products Include:

AC & DC Current Transducers
AC & DC Current Operated Switches
1 ϕ & 3 ϕ Power Transducers
Current & Potential Transformers (CTs&PTs)

500 Division Street, Campbell CA 95008
800-959-4014 or +1-408-871-7510 Phone
+1-408-871-7515 FAX
sales@nktechnologies.com, www.nktechnologies.com



INSTRUCTIONS



ATP SERIES

Powered AC Current Transducers
0-200A Input Range
4-20mA, 0-5VDC, 0-10VDC Output

Quick "How To" Guide

1. Run the wire you are monitoring through aperture.
2. Mount the sensor to a surface if needed.
3. Connect output wiring.
 - A. Use up to 12AWG copper wires.
 - B. 0-5/10 VDC Models: Make sure output load is at least 250 K Ω
4. Chose correct range by positioning the Range Jumper.

Description

The ATP Series powered AC current transducers combine a current transformer and signal conditioning electronics in a single package for use in 120V line-voltage or 24V control power applications. The combination of these devices results in a single unit with higher accuracy, fewer individual terminations, and a space-saving simplified installation.

ATP Series transducers are available in solid- or split-core enclosures and with 4-20mA, 0-5VDC or 0-10VDC analog outputs. Custom input and output ranges may also be available; please consult with the factory. ATP Series transducers are average responding and intended for use in constant or on/off load applications with sinusoid waveforms.

Installation

1. Place wire in which current is to be monitored through aperture of ATP unit.
2. Mount ATP unit using screw holes in mounting base of unit, taking care maintain at least one-inch clearance in all directions between the sensor and other magnetic devices for proper operation. *Note: The transducer is not directionally sensitive and can be mounted in any position or hung directly on wiring with the use of wire ties.*
3. For –SP versions (split-core enclosures) only: Press the tab in the direction as shown to open the sensor. After placing the wire in the opening, press the hinged portion firmly downward until a definite click is heard and the tab pops out fully.

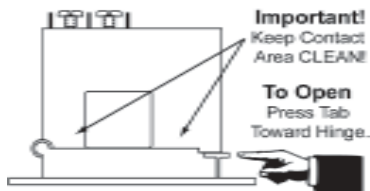

KEEP SPLIT-CORE SENSORS CLEAN.

Silicone grease is factory applied on the mating surfaces to prevent rust and improve performance. Be careful not to allow grit or dirt onto the grease in the contact area. Operation can be impaired if the mating surfaces do not have good contact. Check visually before closing.

Output Wiring

Connect control or monitoring wires to the sensor. Use up to 12 AWG copper wire and tighten terminals to 4 inch-pounds torque.

Connection Notes:

- Deadfront captive screw terminals
- 12-22 AWG solid or stranded.
- Observe Polarity

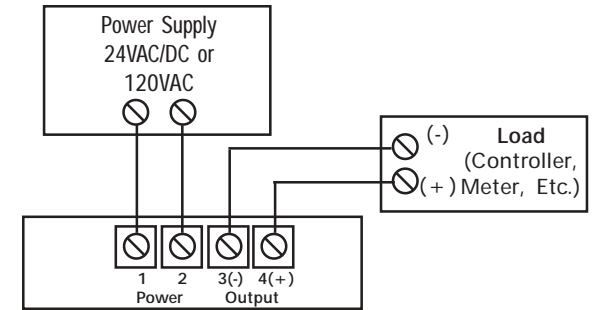

Range Select

ATP Series transducers feature field selectable ranges. The ranges are factory calibrated, eliminating time consuming and inaccurate field setting of zero or span.

1. Determine the normal operating amperage of your monitored circuit.
2. Select the range that is equal to or slightly higher than the normal operating amperage.
3. Place the range jumper in the appropriate position.

Trouble Shooting, 4-20mA Models

1. Sensor has no output

- A. Power supply is not properly sized. *Check power supply voltage and current rating.*
- B. Polarity is not properly matched. *Check and correct wiring polarity*
- C. Split Core models: The core contact area may be dirty. *Open the sensor and clean the contact area.*

2. Output Signal Too Low

- A. Range may be too high for current being monitored. *Select different ATP model with lower range.*
- B. The load current is not sinusoidal. *Select an ATR*

transducer that works on distorted waveforms

- C. Monitored current is below minimum required. *Loop the monitored wire several times through the aperture until the “sensed” current rises above minimum. Sensed Amps = (Actual Amps) x (Number of Loops). Count loops on the inside of the aperture.*

3. Sensor is always at 4mA

- A. Monitored load is not AC or is not on. *Check that the monitored load is AC and that it is actually on.*

4. Output Signal is always at 20mA

- A. Range may be too low for current being monitored. *Select different ATP model with higher range.*

Trouble Shooting, 0-5 and 0-10 VDC Models

1. Sensor has no output

- A. Polarity is not properly matched. *Check and correct wiring polarity*
- B. Monitored load is not AC or is not on. *Check that the monitored load is AC and that it is actually on.*
- C. Split Core models: The core contact area may be dirty. *Open the sensor and clean the contact area.*

2. Output Signal Too Low

- A. The jumper may be set in a range that is too high for current being monitored. *Move jumper to the correct range.*

- B. Output load too low. *Check output load, be sure it is at least 250KΩ.*

- C. Monitored current is below minimum required. *Loop the monitored wire several times through the aperture until the “sensed” current rises above minimum. Sensed Amps = (Actual Amps) x (Number of Loops). Count loops on the inside of the aperture.*

3. Output Signal is always at maximum

- A. The jumper may be set in a range that is too low for current being monitored. *Move jumper to the correct range.*