

Installation & Wiring

AGLD Series relays work in the same environment as motors, contactors, heaters, pull-boxes, and other electrical enclosures. They can be mounted in any position or hung directly on wires with a wire tie. Just leave at least one inch distance between relay and other magnetic devices. Run all current carrying conductors through the opening in the relay. (See "Principal of Operation") Be Sure all wires are oriented so current flows in the same direction.

Test Switch

Pressing the test button will cause the output to change state. This may operate the connected load depending on your control scheme.

Operation

AGLD Series Auto Reset Ground fault relays operate in one of two states: Normally de-energized (DEN) or Normally energized (ENE).

DEN Sensors produce a change in the relay contacts ONLY when there is a fault over the trip point. ENE Sensors provide contact action when the sensor is powered, so the contact state will return to the original condition with fault detected or with a loss of power to the sensor.

Testing

To test operation, gently press the TEST button. This simulates a fault and tests the internal switching circuits.

CAUTION: Any circuit connected to the relay will be operated.

The open contact closes on sensed fault current over the set point (or test), and the closed contact opens on detected fault.

Upon detecting a fault or when the TEST switch is pressed, the output will switch.

The output will reset to the original (energized) state after the TEST button has been depressed.

To indicate that the sensor has sensed a fault, the LED display will flash until the fault has cleared.

Wiring

Use up to 14 AWG copper wire and tighten terminals to 5.3 inch-pounds torque. See Diagrams.

Power

Connect power wiring to Terminals 1-2 (Auto-reset) or 3-4 (Latching). Be sure that the power supply matches the power rating on the relay label. Green LED Display will light with power applied. The input is not polarity sensitive.

Output

Connect output wiring to Terminals 3-4 (NO) or 5-6 (NC) (Latching models: NO 5-6 and NC 7-8)

Field Setpoint Adjustment

The AGLD sensors provide an easy method to set the amount of fault current which will cause the output to change state. There is a white slotted adjustment knob to the left of the TEST button. This is a linear, single turn potentiometer allowing the trip point to be set at a minimum of 5mA by turning counterclockwise, and 100mA clockwise. The LED display will show the trip point in mA at any time the sensor is powered, except when adjusting the output delay.

Time Delay Adjustment

The delay adjustment is located on the lower left side on the top of the sensor, directly below the trip point adjustment. Turning the slotted knob fully counterclockwise to set the delay to the minimum (30ms to activate the output contacts) and the amount of added delay will be shown on the LED display. After one second, the display will revert from showing the amount of added delay to displaying the trip point. Note that the display shows the delay in ms, but with the decimal point one place to the left. The delay can be increased by turning the adjustment clockwise, and the display will show 00 with no added delay, up to 99, representing 990ms of added delay after a fault is detected.

When used with an external CT, the relay will be set to trip at a point much lower than without the CT. How much fault current will cause the output to change state will depend on the external current transformer used. Please contact the factory for information.

The AGLD sensor provides a window with ID of 1.76 inches (or 44.7mm). This allows a maximum of four 250MCM THHN to pass through. The formula to calculate if there will be room for the wires follows:

Measure the OD of one wire. Use this measurement multiplied by 2.15 to obtain the OD of a bundle of three, and by 2.41 for the OD of bundle of four wires. Please contact the factory for more information.

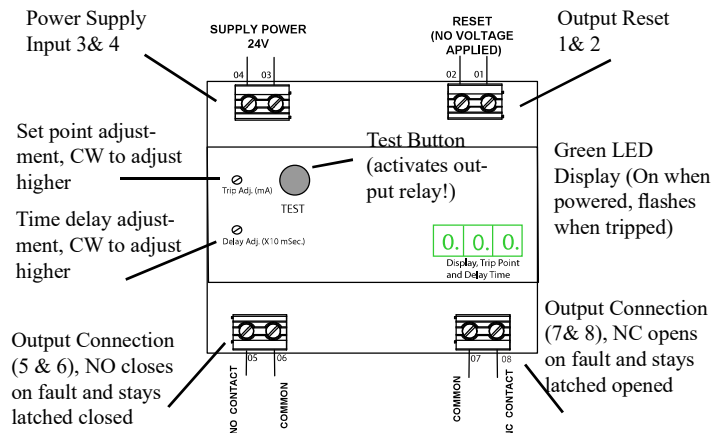
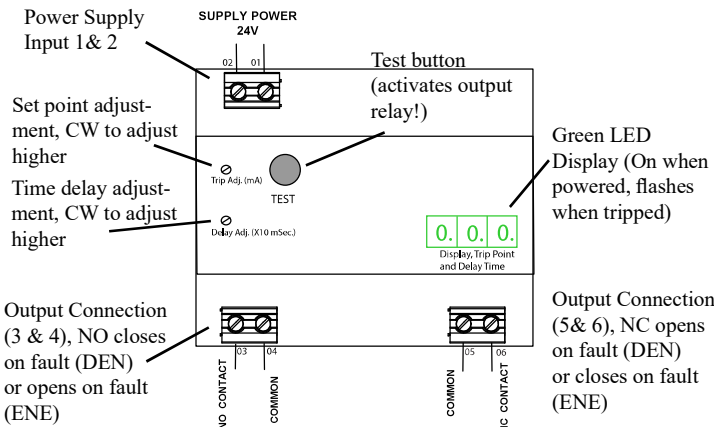

Contact Action		Control Power Applied		
Model	Contact State	No Power	No Fault	Fault Detected
ENE	Norm. Open	Open	Closed	Open
	Norm. Closed	Closed	Open	Closed
DEN	Norm. Open	Open	Open	Closed
	Norm. Closed	Closed	Closed	Open
LA	Norm. Open	Open	Open	Latch Closed
	Norm. Closed	Closed	Closed	Latch Open