

Monitoring Power with Flexible Cable Type Current Transformers

Measuring the watts used by a load will help with cost allocation, allowing a plant manager to charge a specific process or department for the energy consumed, along with providing the means to detect maintenance issues such as bearing failure and pump impeller cavitation. A bearing which is not running smoothly causes the drive motor to require more power to turn the supported shaft, while the bubbles formed during cavitation reduces the amount of torque, resulting in lower power usage.

The flexible cable current sensing method, often referred to as Rogowski coils, was refined in 1912 by engineers Walter Rogowski and W. Steinhaus. This method of measuring AC current has some very attractive features. There is no iron core, making the device much lighter and easier to install than toroid-based current transformers. Since there is no permeable core the coils cannot be saturated with high current conditions making them just as accurate with higher circuit frequencies (up to 1MHz) as when monitoring 60 Hz. The flexibility allows the cable to surround multiple conductors or bus assemblies regardless of the shape.

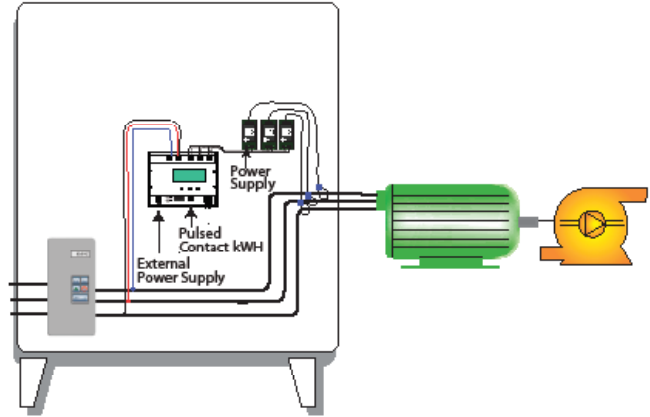

Power Monitoring Applications

- Motors
Measure motor power consumption when current alone provides insufficient resolution.
- Machine Tools
Monitor finishing operations such as deburring.
- Car Wash Systems
Sense brush entanglements.
- Pumping Systems
Detect dry run, blocked intake or discharge lines, bearing failures and cavitation.
- Cost Allocation
Monitor the power usage of each machine, process, building or the entire facility.

CTRC Current Transformer for Power Monitoring

NK Technologies' CTRC current transformers use the Rogowski coil as the first step in power monitoring. Each coil is matched with a signal integrator, and the output is calibrated for the highest degree of accuracy possible. The resulting 1/3 volt at full range current mirrors the primary circuit wave shape with less than 0.5 degree difference in the phase angle and overall linearity of better than 1% of the full scale output. When matched with the circuit voltage wave shapes, a highly accurate representation of the system power, measured in watts, can be derived.

The signal integrator is housed in a compact, DIN-compatible enclosure, with 1.5 meter (59 inches) of lead cable from the sensing loop to the integrator. The signal integrator is powered with 24 volts, AC or DC, consuming less than one watt each. The narrow dimension of the lead cable (0.87 inches) allows for installation in very close quarters, easily passing between the monitored conductor and the adjacent phase. The coils are rated to 600 VAC and do not require shorting blocks between the integrator and the connected load. Even when the current through the loop exceeds the design range the low voltage output remains at non-hazardous levels.

